

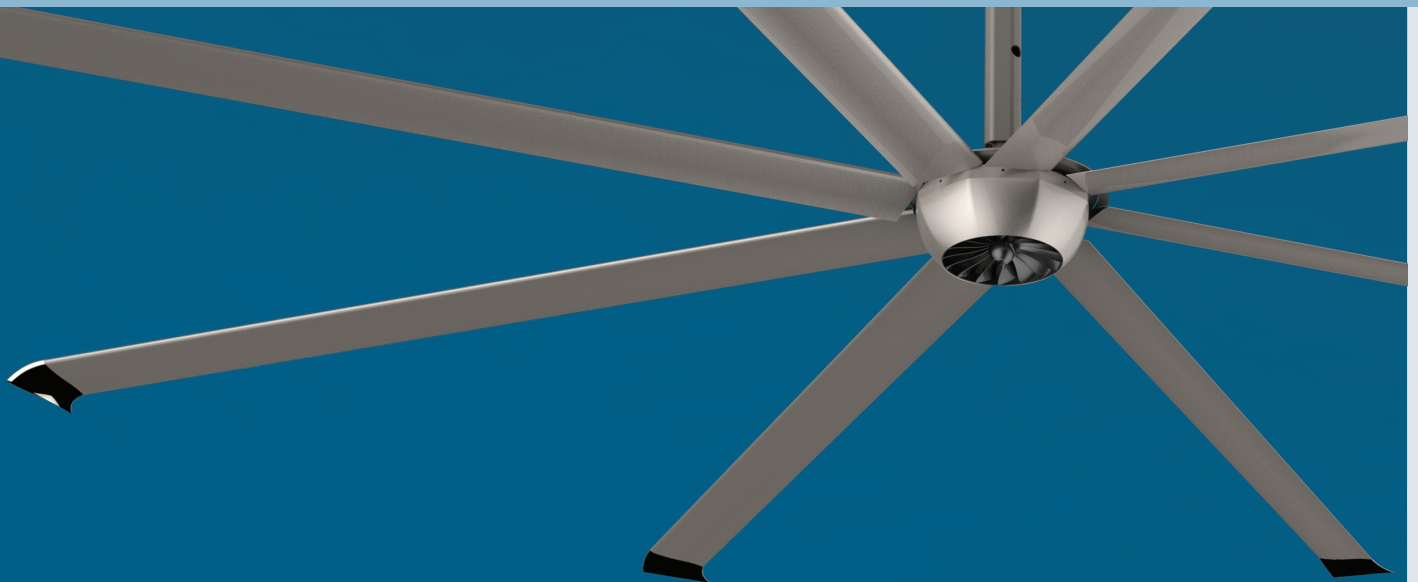

MAMMOTH FANS

COMMERCIAL SERIES

INSTALLATION • OPERATION • MAINTENANCE • WARRANTY INFORMATION



INSTRUCTION MANUAL

SKU 211402 & 211403

CAUTION

READ INSTRUCTIONS CAREFULLY FOR SAFE
INSTALLATION AND FAN OPERATION.

CONGRATULATIONS ON YOUR PURCHASE

Congratulations on your purchase of a Mammoth Fan. The Mammoth fan range features world class Permanent Magnetic Synchronous (PMSM) technology and precision-led aeronautical design in Mammoth Proportions.

With energy efficiency, design and ultimate performance in mind, Mammoth Fans have developed the latest in High Volume Low Speed (HVLS) ceiling fans for large residential, commercial and industrial spaces to suit Australian conditions.

Whether it is large outdoor alfresco spaces, industrial warehouses, agricultural buildings, gymnasiums, halls or public spaces, Mammoth Fans has the perfect solution for your project. With market leading features of supreme efficiency, low noise and minimal maintenance, easy installation and advice backed by a 5 year warranty, Mammoth Fans are here to keep you cool.

The Mammoth fan you have purchased is a sophisticated electrical device, all care must be taken to ensure the fan is kept clean and not mistreated as issues arising will not be covered under the warranty.

SAFETY PRECAUTIONS

1. Always ensure the power is OFF before performing installation, maintenance, cleaning or making any adjustment to the fan.
2. Must be assembled and installed by a licensed electrician.
3. All wiring and installation of the fan must adhere to the latest local and national wiring rules. eg. AS/NZS 3000 Electrical installations.
4. The appliance is not intended for use by persons (including children) with reduced physical, sensory or mental capabilities, or lack of experience and knowledge, unless they have been given supervision or instruction concerning the use of the appliance by a person responsible for their safety.
5. Children should be supervised to ensure that they do not play with the appliance.
6. An all-pole disconnection switch must be incorporated into the fixed wiring, in accordance with local wiring rules.
7. The structure to which the fan is to be mounted must be capable of supporting **2 times** the weight of the product and its own structural loading. Check with a structural engineer if unsure.
8. Please do not alter the structure of the install site without prior advice of a structural engineer.
9. The fan should be mounted so that the blades are at least 3.5m above the floor.
10. This fan is suitable for covered alfresco use.
11. The Mammoth Fan must be installed with the electrical control box supplied.
12. During installation, adjustment and cleaning ensure the blades are not bent as this will drastically impact the performance of the fan.
13. Please make sure the fan's input voltage and supply voltage are the same before cut-in the power.
14. Please do not open the electrical control box without first isolating the power as electrical shock may occur.
15. Please do not operate the fan if you notice any damage or noises to/from the fan
16. The control box is a sophisticated controller designed specifically for the Mammoth Fans.
No modifications to the controller are permitted and failure to follow this advice could cause injury or death.
- 17. Within the electrical control box is a high-voltage storage capacitor. When you operate the fan, please wait for 3 minutes to let the voltage discharge to prevent electric shock.**
18. Ensure sufficient clearance around the fan and NO obstructions before starting up the fan. Failure to do so will cause significant damage and will not be covered under the warranty.
19. Ensure not to cut off the power to the fan while it is in operation. Please stop the fan first then isolate the power.

1. General parts

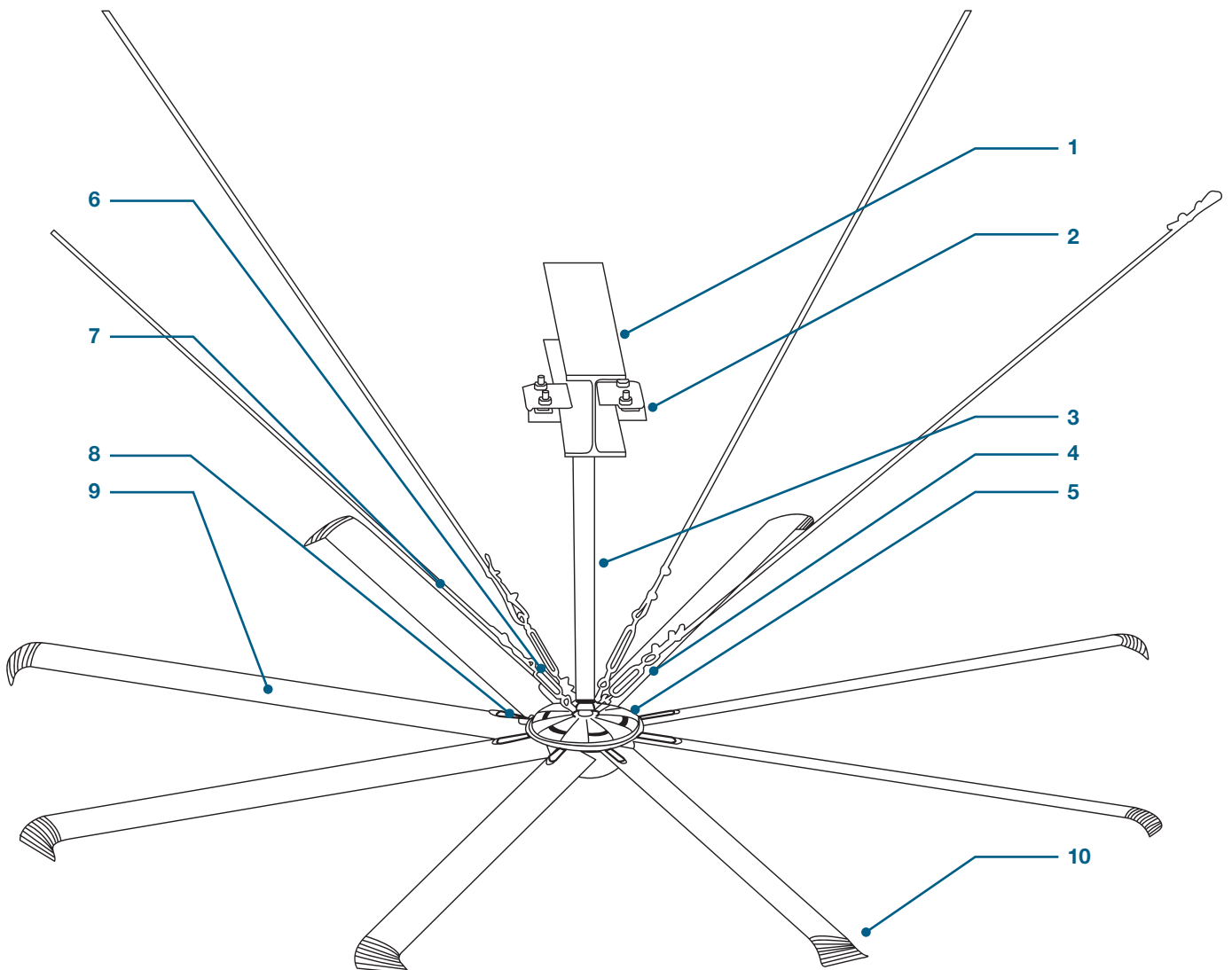

1. I-type steel structure

2. Clamp plate

3. Extension tube

4. Turnbuckle and clamps

5. PMSM motor

6. Separating connector

7. Steel wire

8. L-type adapting pieces

9. Fan blade

10. Fan blade tip



PARTS LIST

2. Standard component parts

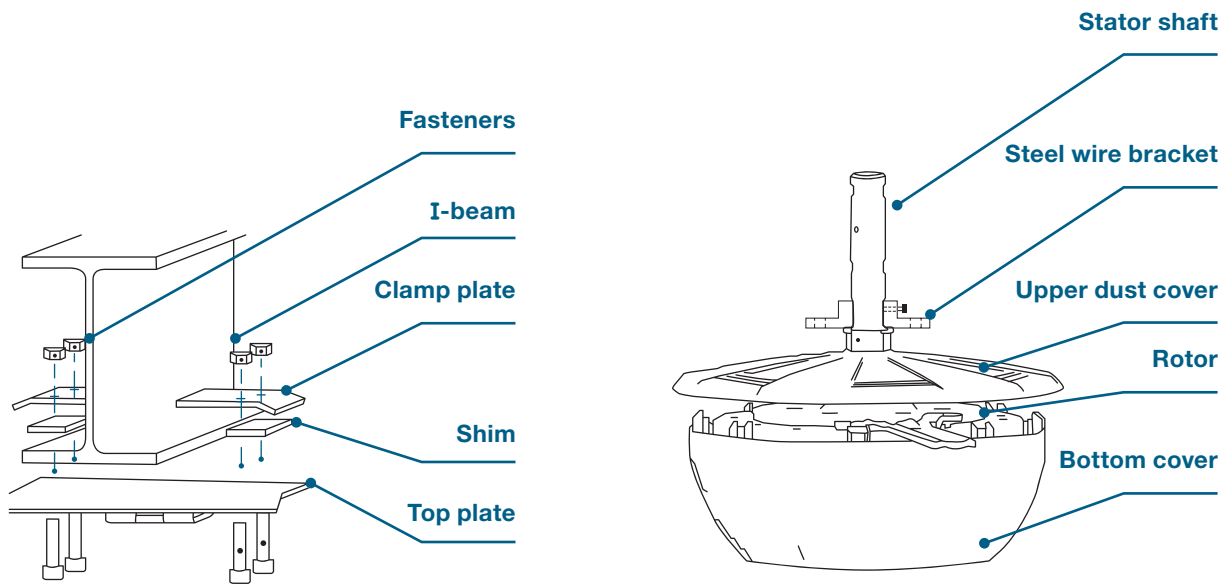

3. Control unit



PARTS LIST

4. Packing list

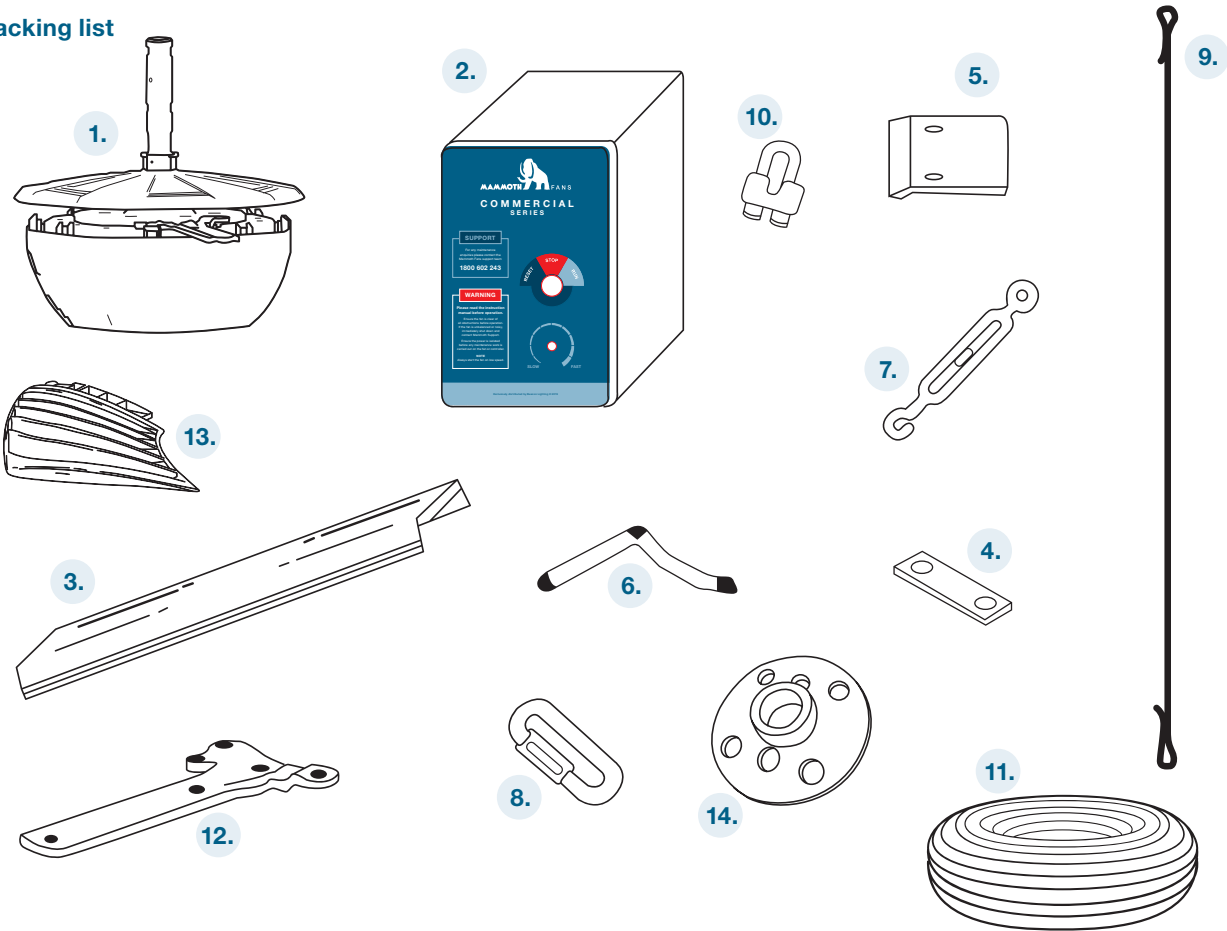

PACKING SPECIFICATION

CASE NO	DIMENSIONS (LxWxHmm)	Volume (m ³)	Gross weight (kg)	Remark
1	1000 x 430 x 390	0.16	70	Main body carton

NO.	DESCRIPTION	NO.	DESCRIPTION
1	PMSM motor system	8	Adapter Ring
2	Control Box	9	Steel Wire
3	Top Plate	10	Fastener
4	Shim	11	Cable
5	Clamp Plate	12	Blade Connector
6	L-type Adapting Pieces	13	Fan Blade Tip
7	Turnbuckle	14	Steel wire bracket



PARTS LIST

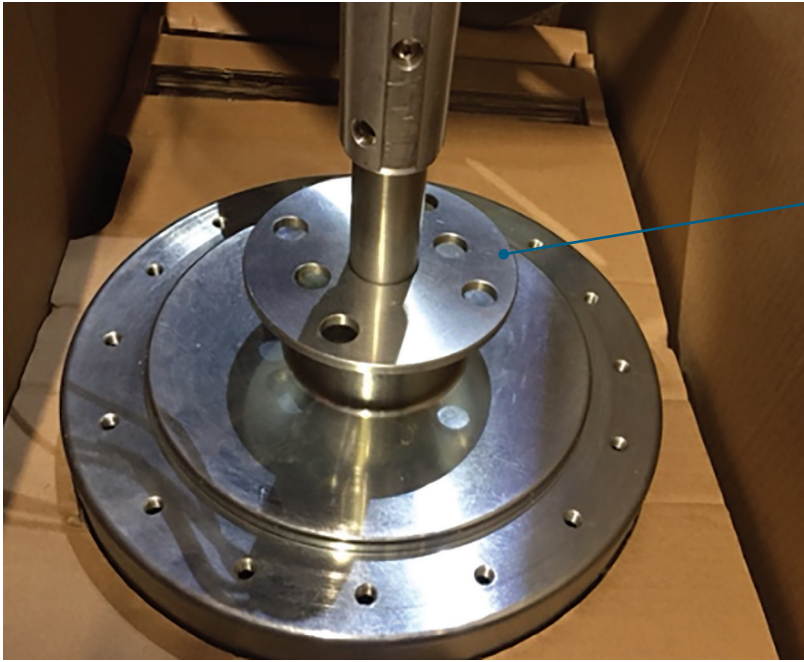

14. Steel wire bracket

Part 14. NOTE: This is the steel wire bracket. Please make sure it is installed before installing the fan motor part to the extension rod.

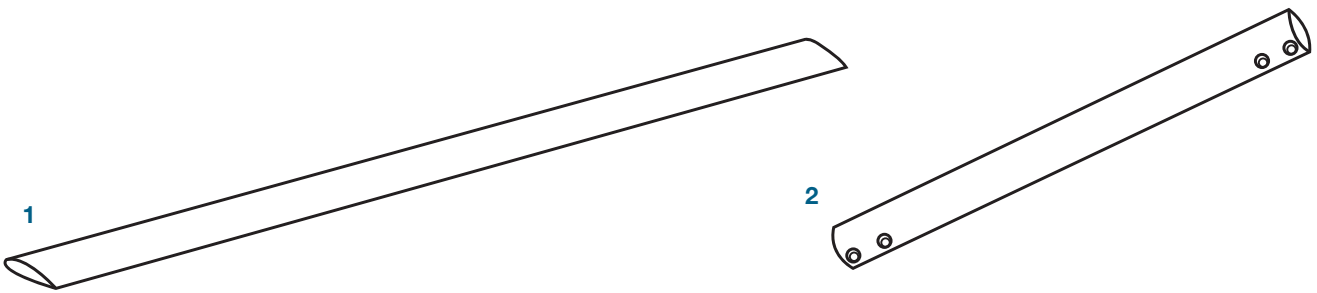

PACKING SPECIFICATION

CASE NO	DIMENSIONS (LxWxHmm)	Volume (m ³)	Gross weight (kg)	Remark
2	1890 x 270 x 180	0.1	28	Fan blade carton

PACKING DETAILS

NO.	DESCRIPTION
1	Fan Blade
2	Extension Tube

PARTS LIST

5.Required Installation tools



ADJUSTABLE WRENCH



SOCKET WRENCH



LASER DISTANCE MEASURE



LEVEL



ALLEN KEYS



MULTIMETER



WIRE-CUTTER



SCREW GLUE



INSTALLATION REQUIREMENT

1. Roof installation requirement

The Mammoth Fan must be installed in a location so that the blades have enough space between the fan and the nearest objects or walls. (Refer to the below diagram for detail spacing requirement). Secure the hanging bracket to the ceiling joist or structure with bolts & nuts provided. Ensure there are 3 - 4 threads left on the bolt after tighten the nut. The structure to which the fan is to be mounted must be capable of supporting 2 times the weight of the product and its own structural loading. Check with a structural engineer if unsure.

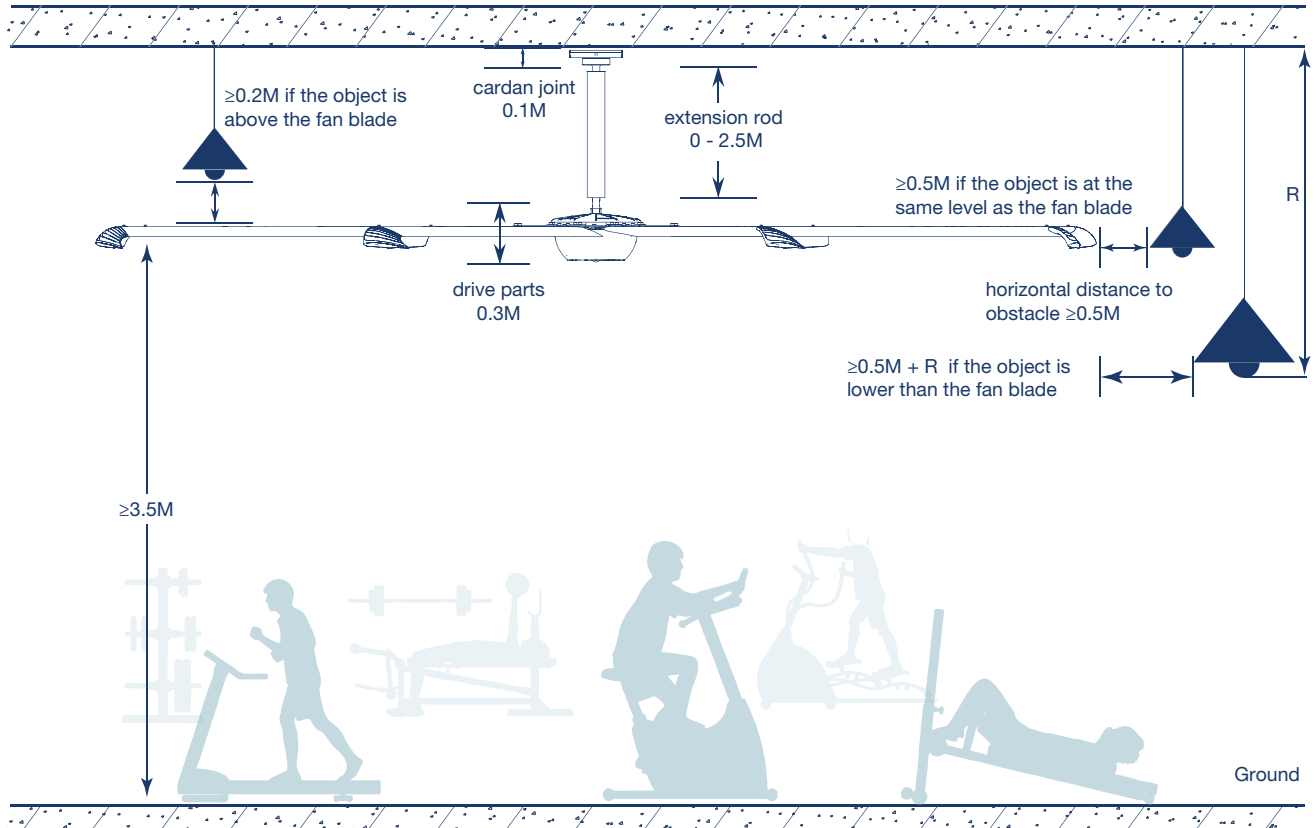

NOTE: be cautious of items like light fittings which may swing into the path of the spinning fan, ensure appropriate clearance is maintained.

2. I-Beam Steel structure (Included as standard)

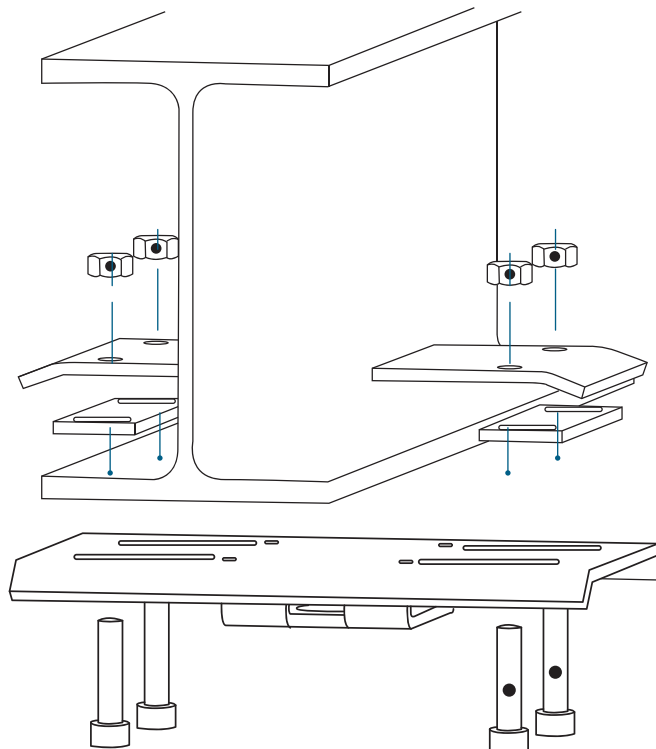

3. Concrete structure
(This accessory sold separately)

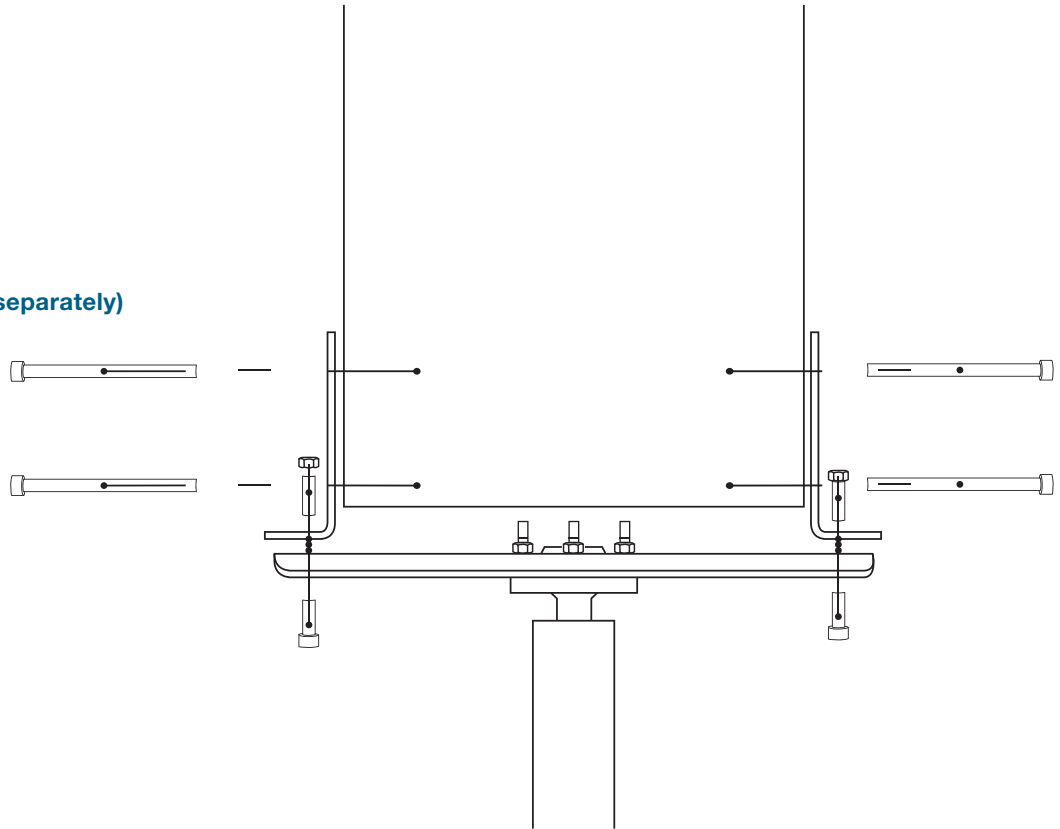

4. Steel, concrete or Timber beam structure
(This accessory sold separately)

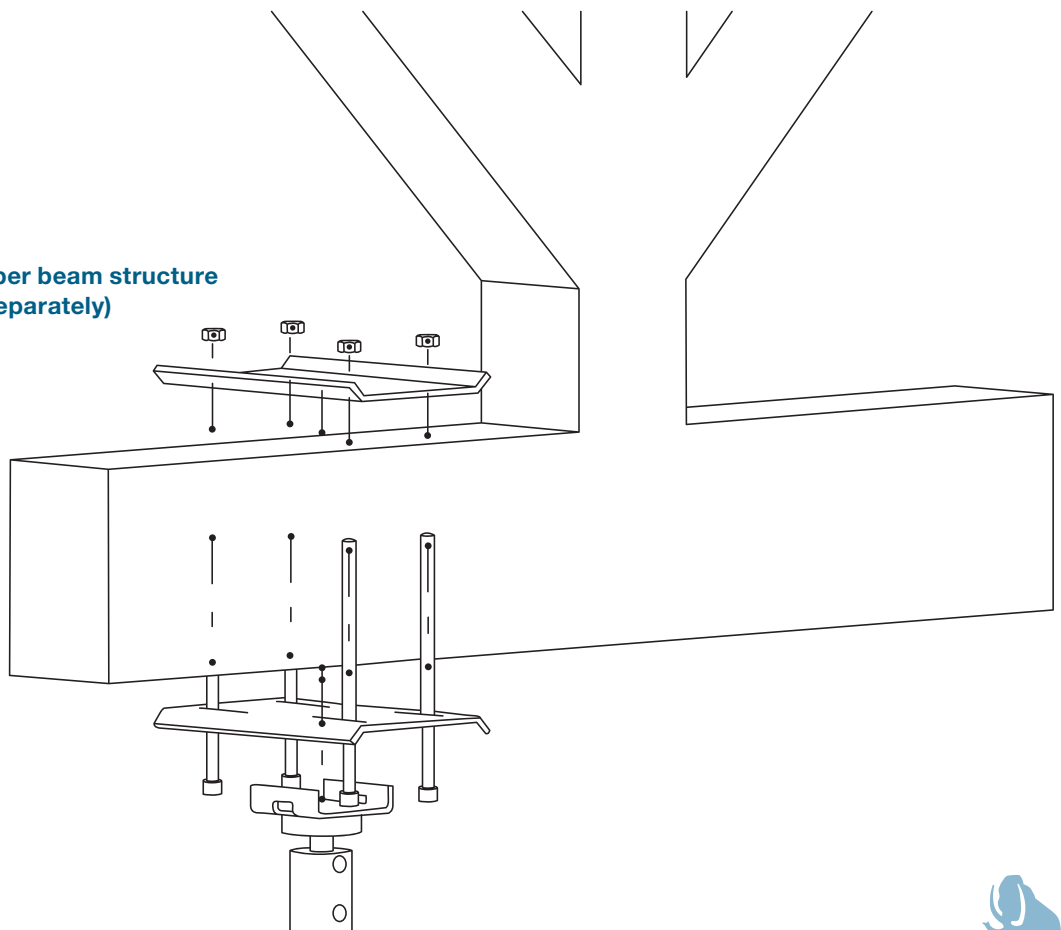

FAN INSTALLATION

1. PREPARATION

Carefully unload and position the fan on the ground in a location that won't be impacted by ladders, scissor lifts or personnel.

2. PLAN

Carefully plan and consider the following information

1. Installation point
2. Installation height
3. Whether there are obstacles (such as, lights, cable, fire protection, cameras, forklift access etc.)
4. The position of the control box
5. The input power and design of your electrical layout
6. Traction steel wire position

3. SAFETY

Ensure power is isolated to the area that you are working. Ensure safe practices are followed in regards to working at heights and lifting heavy equipment. Follow appropriate guidelines and regulations in your region.

4. TOP PLATE

Fastening the top plate to the H beam, ensuring a tight connection between the beam and the plate. Screw glue (Loctite or similar) should be used.

5. EXTENSION TUBE

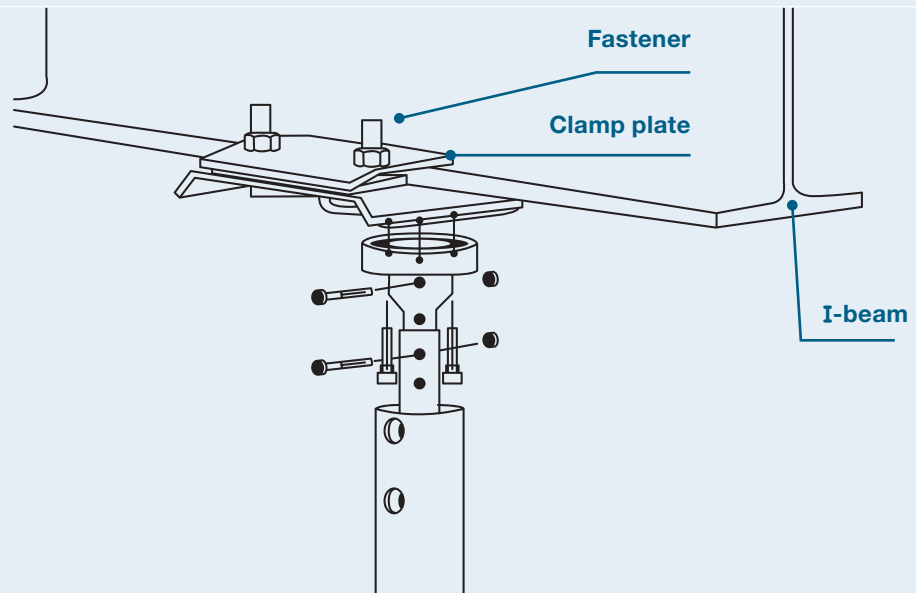

6. POWER CABLE

Ensure you have sufficient length of the cable coming from the extension tube.

7. MAIN BODY

Ensure bolts are horizontal before tightening the main body to the extension tube.

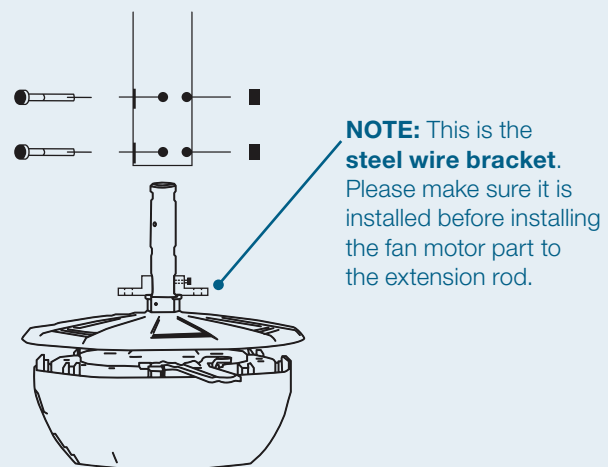

8. WIRING

Make the appropriate electrical connection to the fan body, ensure neat and tight connections are completed.

FAN INSTALLATION

9. STEEL WIRING

Important – support wires should be evenly spaced in 4 opposing directions, to evenly distribute any stress and movement. Wire clamps should be secure and glued with screw glue (Loctite or similar)

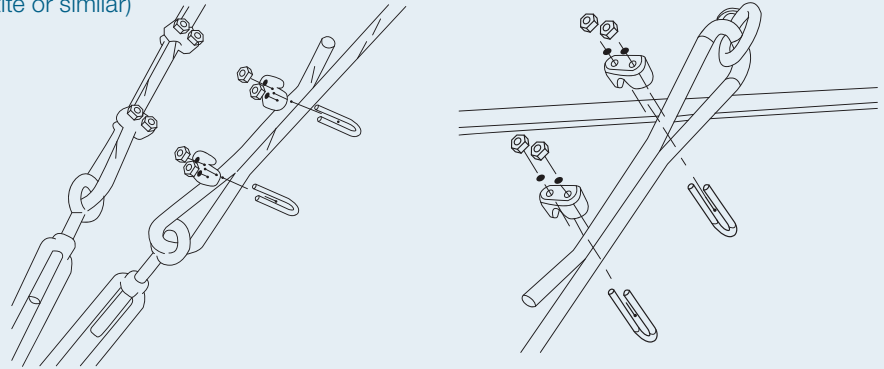

10. POWER CABLE

Wiring should be to local regulations

11. FAN BLADES

Fan blades should be mounted one after the other in opposites to each other, two people will be required to effectively mount and tighten the fan blades and safety support screws. This procedure must be done while the fan motor is mounted on the ceiling. Trying to complete this on the floor then mounting the fan will cause damage to the blades.

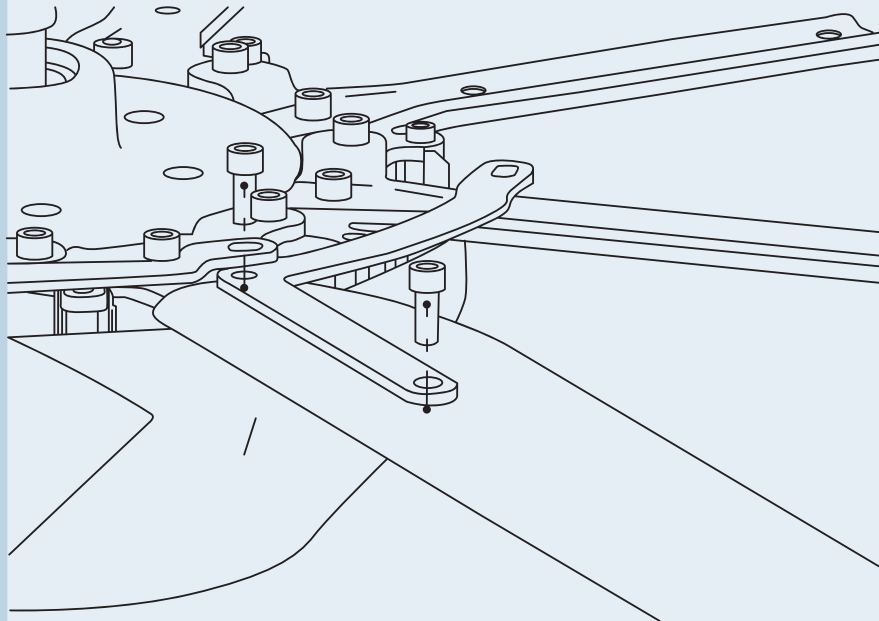

12. FAN BLADE TIP INSTALLATION

Fan Blade Tip

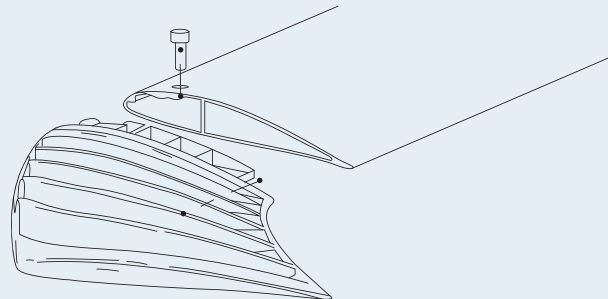

13. CONTROL BOX

The height from floor to the bottom of the control box should be around 1.2 meters and in a safe and practical position

14. WIRING

Distinguish the input and output, also make sure the ground wire is in place, wire to local wiring standards.



FAN INSTALLATION

15. DEBUGGING

Each Mammoth fan is tested prior to leaving the factory, if there seems to be a problem double check all electrical connections, and contact the Mammoth support team.

16. COMMISSIONING

Use a spirit level and ensure blades are level before switching on. Run the fan for 15mins and observe, is it spinning in the correct direction (anti-clockwise for summer), listen for any abnormal noise, ensure there is no movement in the support cables. Check the current is within the rated range.

17. HANDOVER

Ensure the customer is instructed on how to operate and isolate the fan.

ELECTRICAL WIRING DIAGRAM

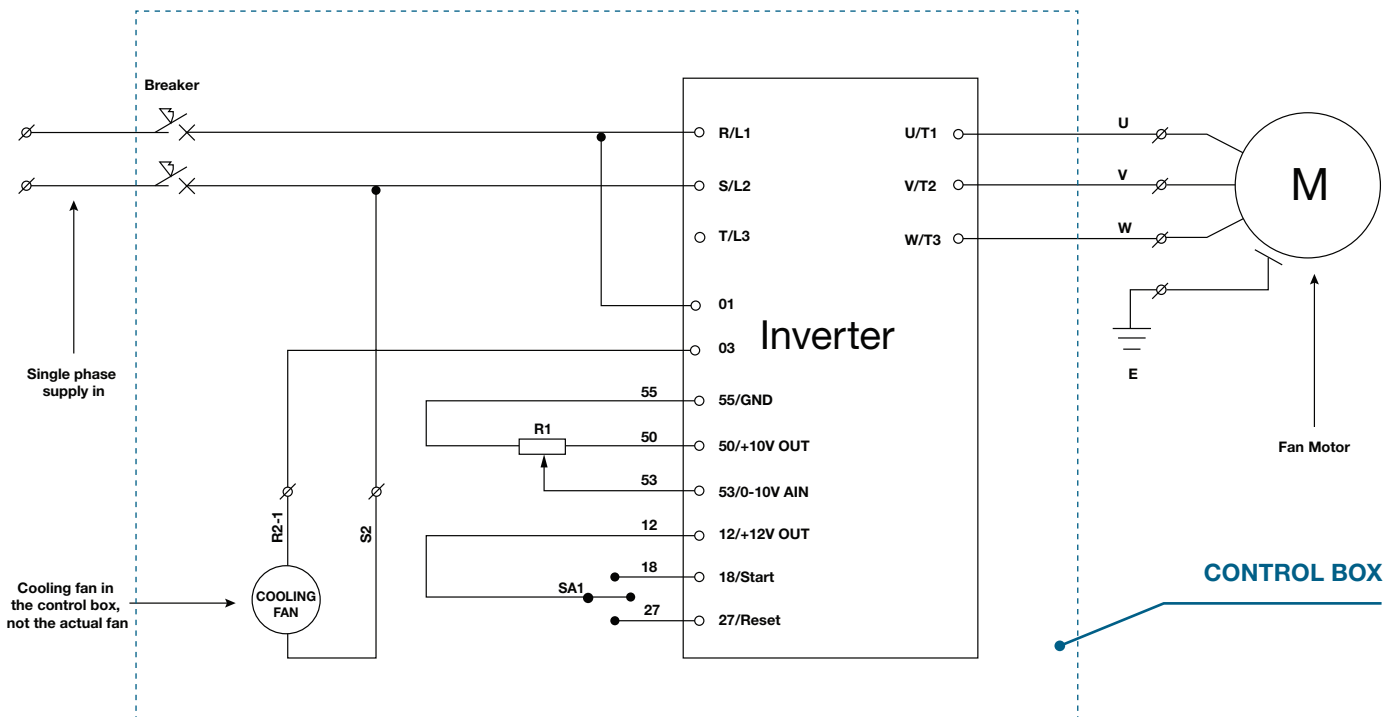



SPECIFICATION OF PARAMETERS FOR CONTROL SYSTEM

STATUS DISPLAY

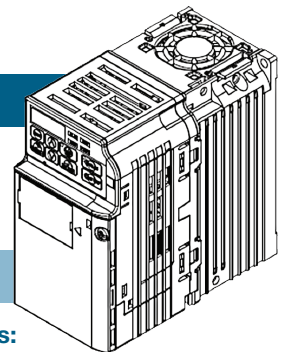

















When the power supply to the drive is turned on, the LED operator lights will appear as follows:

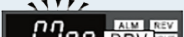

NO.	Name	DESCRIPTION
Normal Operation		The data display area displays the frequency reference DRV is lit.
Fault	 Main circuit low voltage (ex)	Data displayed varies by the type of fault. For more information and possible solution ALM and DRV are lit.

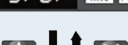
NAVIGATING THE DRIVE AND PROGRAMMING MODES

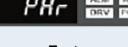
The drive is set to operate in Drive Mode when it is first powered up. Switch between display screens using **▲** and **▼**

NO.	Name	DESCRIPTION
Power Up	<p>Frequency Reference</p>  <p>Default Setting</p>	<p>This display screen allows the user to monitor and set the frequency reference while the drive is running. Note: The user can select items to display when the drive is first powered up by setting parameter o1-02.</p>
Drive Mode	 <p>Forward/Reverse</p> 	<p><i>For</i>: Motor rotates forward <i>Rev</i>: Motor rotates in reverse. Note: For applications that should not run in reverse (fans, pumps, etc.), set parameter b1-04= "1" to prohibit the motor from rotating in reverse. This sequence also puts the drive in LOCAL mode.</p>
Drive Mode	 <p>Output Frequency Display</p>   <p>Output Current Display</p>  	<p>Monitors the frequency output of the drive.</p> <p>Monitors the output current of the drive.</p>
Drive Mode	<p>Output Voltage Reference</p>   <p>Monitor Display</p> 	<p>Monitors the output voltage of the drive.</p> <p>Monitor parameters (U parameters) are displayed.</p>
Programming Mode	 <p>Verify Function</p>   <p>Setup</p>   <p>Parameter Setting</p>  	<p>Lists all parameters that have been edited or changed from default settings.</p> <p>A select list of parameters necessary to get the drive operational quickly.</p> <p>Allows the user to access and edit all parameter settings.</p>
Drive Mode	<p>Frequency Reference</p> 	<p>Returns to the frequency reference display screen.</p>



OPERATING INSTRUCTION

Function switch on control box this feature sets the device to reset – stop – run operating process is as follows

1. Ensure there are no obstructions or potential danger before switching the fan on
2. Turn the speed dial to the minimum setting
3. Turn the control dial from Stop to Run position
4. After the fan starts rotating, adjust the speed control to your desired level.

Shutdown Process

1. Turn the control dial from Run to Stop



WARNING

Please read the instruction manual before operation.

Ensure the fan is clear of all obstructions before operation. If the fan is unbalanced or noisy, immediately shut down and contact Mammoth Support.

Ensure the power is isolated before any maintenance work is carried out on the fan or controller.

NOTE

Always start the fan on low speed.

Switch

Speed controller

CLEANING & MAINTENANCE

Cleaning & maintenance

1. Please ensure the power to the Mammoth fan is isolated before completing any cleaning and maintenance work. Also ensure you follow all local regulations in regards to safe working at heights practices. Periodic cleaning of your ceiling fan is the only maintenance required. Use a soft brush or lint free cloth to avoid scratching the paint finish.
2. A damp cloth can be used to wipe down the blades, however ensure not to allow excess water to enter any wiring connections, this could damage the fan and cause a safety issue.
3. Ensure that the fitting does not come in contact with any organic solvents or cleaners.
4. The motor has a permanently lubricated ball bearing which does not require maintenance or re-oiling.

TECHNICAL INFORMATION

SKU#	211402	211403
Model No.	SHVLS-D8BAA42	SHVLS-D8BAA30
Diameter	4.2m	3.0m
Rated voltage	220-240V~ 50Hz	220-240V~ 50Hz
Rated power	400W	200W
Full load current	1.8A	1.3A
Max. Speed	80RPM	100RPM
Air volume at max. speed	7550m ³ /min	5530m ³ /min
Climate class	T - Tropical	T - Tropical
Weight	41kg	35kg



TROUBLESHOOTING

Common causes for the malfunctioning operation

1. The external power supply of the control box is not within the range appropriate for the controller
2. Ensure there is power to the controller box, turn speed dial to Minimum setting (SLOW), Turn the control dial to Run. If this doesn't work return the control dial to reset, then return dial to Stop, and finally to Run.
3. If on start up you notice any unusual sounds coming from the fan or the controller immediately return the control dial to Stop and contact the Mammoth Support team.
4. Equipment damage due to the improper use is not covered by the warranty. Mammoth Fans will not be responsible for personal injuries and equipment damages for failure to comply with the contents of this manual.

Explanation of the error codes:

On the Control box when a minor fault or alarm occurs, the ALM LED will flash and the text display will show an alarm code.

A fault has occurred if the text remains lit and does not flash, first turn the switch to STOP, then to RESET, and review the fault reason codes below.

Please note many of the error codes will require a technician to review, please contact your electrician or the Mammoth Support team, never attempt to troubleshoot if you are not trained to do so.

LED Operator Display		Name	Minor Fault Output (H2-01 = 10)
<i>bb</i>	bb	Drive Baseblock	No output
<i>CALL</i>	CALL	Serial Communication Transmission Error	YES
<i>CE</i>	CE	MEMOBUS/Modbus Communication Error	YES
<i>CrST</i>	CrST	Cannot Reset	YES
<i>EF</i>	EF	Run Command Input Error	YES
<i>EF1 to EF5</i>	EF1 to EF5	External Fault (input terminal S1 to S5)	YES
<i>oH</i>	oH	Heatsink Overheat	YES
<i>oL3</i>	oL3	Overtorque 1	YES
<i>ou</i>	ov	Overvoltage	YES
<i>PASS</i>	PASS	MEMOBUS/Modbus Test Mode Complete	No output
<i>SE</i>	SE	MEMOBUS/Modbus Test Mode Fault	YES
<i>Uu</i>	Uv	Undervoltage	YES

TROUBLESHOOTING

LED Operator Display		Fault Name
	oC	Overcurrent Drive sensors have detected an output current greater than the specified overcurrent level.
Cause		Possible solution
One of the motor cables has shorted out or there is grounding problem.		<ul style="list-style-type: none"> • Check the motor cables. • Remove the short circuit and power the drive back up. • Check the resistance between the motor cables and the ground terminal. • Replace damaged cables.
The load is too heavy.		<ul style="list-style-type: none"> • Measure the current flowing into the motor. • Replace the drive with a larger capacity unit if the current value exceeds the rated current of the drive. • Determine if there is sudden fluctuation in the current level. • Reduce the load to avoid sudden changes in the current level or switch to a larger drive.
The motor cable is too long.		Use a larger drive

LED Operator Display		Fault Name
	ov	Overvoltage Voltage in the DC bus has exceeded the overvoltage detection level. <ul style="list-style-type: none"> • For 200 V class: approximately 410V. • For 400 V class: approximately 820V (740V when E1-01 is less than 400).
Cause		Possible solution
Deceleration time is too short and regenerative energy flows from the motor into the drive.		<ul style="list-style-type: none"> • Increase the deceleration time (C1-02, -04, -06, -08). • Install a braking resistor or a dynamic braking resistor unit. • Enable stall prevention during deceleration (L3 04="1"). Stall prevention is enabled as the default setting.
Fast acceleration time causes the motor to overshoot the speed reference.		<ul style="list-style-type: none"> • Check if sudden drive acceleration triggers an overvoltage alarm. • Increase the acceleration time. • Use longer S-curve acceleration and deceleration times.
Excessive braking load.		The braking torque was too high, causing regenerative energy to change the DC bus. Reduce the braking torque, use a braking option, or lengthen decel time.
Drive input power voltage is too high.		<ul style="list-style-type: none"> • Check the voltage. • Lower drive input power voltage within the limits listed in the specifications.

LED Operator Display		Fault Name
	CPF03	PWM Data error. There is a problem with the PWM data.
Cause		Possible solution
Drive hardware is damaged		Replace the drive.



TROUBLESHOOTING

LED Operator Display		Fault Name
<i>Uv1</i>	Uv1	<p>DC Bus Undervoltage</p> <p>One of the following conditions occurred while the drive was in operation.</p> <ul style="list-style-type: none"> • Voltage in the DC bus fell below the undervoltage detection level (L2-05). • For 200 V class: approximately 190V (160V for single phase drives). • For 400 V class: approximately 380V (350V when E1-01 is less than 400). <p>The fault is output only if L2-01 = 0 or L2-01 = 1 and the DC bus voltage is under L2-05 for longer than L2-02</p>
Cause		Possible solution
Input power phase loss.		<ul style="list-style-type: none"> • The main circuit drive input power is wired incorrectly. • Correct the wiring.
One of the drive input power wiring terminals is loose.		<ul style="list-style-type: none"> • Ensure there are no loose terminals • Apply the tightening torque specified in this manual to fasten the terminals.
There is a problem with the voltage from the drive input power.		<ul style="list-style-type: none"> • Check the voltage • Correct the voltage to within range listed in drive input power specifications.
The power has been interrupted.		Correct the drive input power.
The drive input power transformer is not large enough and voltage drops after switching on power.		Check the capacity of the drive input power transformer.

LED Operator Display		Fault Name
<i>PF</i>	PF	<p>Input Phase Loss</p> <p>Drive input power has an open phase or has a large imbalance of voltage between phases. Detected when L8-05=1 (enabled).</p>
Cause		Possible solution
There is phase loss in the drive input power.		<ul style="list-style-type: none"> • Check for wiring errors in the main circuit drive input power. • Correct the wiring.
There is loose wiring in the drive input power terminals.		<ul style="list-style-type: none"> • Ensure the terminals are tightened properly. • Apply the tightening torque specified in the manual to fasten the terminals.
There is excessive fluctuation in the drive input power voltage.		<ul style="list-style-type: none"> • Check the voltage from the drive input power. • Review the possible solutions for stabilizing the drive input power. • Disable Input Phase Loss Detection (L8-05= "0"). PF is detected if DC bus ripple is too high. If it is disabled, there is no fault but the ripple is still too high, thereby the capacitors are stressed more and lose lifetime

TROUBLESHOOTING

LED Operator Display		Fault Name
<i>oL1</i>	oL1	Motor Overload The electrothermal sensor tripped overload protection.
Cause		Possible solution
Load is too heavy.		Reduce the load.
<ul style="list-style-type: none"> • Drive overloaded at low speeds. • Overload may occur at low speeds when using a general-purpose motor, even if operating within the rated current limitation. 		<ul style="list-style-type: none"> • Reduce the load • Increase the speed • If the drive is suppose to operate at low speeds, either increase the motor capacity or use a motor specifically designed to operate with the drive.
Multiple motors are running off the same drive.		<ul style="list-style-type: none"> • Disable the motor protection function (L1-01="0" and install a thermal relay to each motor.

LED Operator Display		Fault Name
<i>oL2</i>	oL2	Drive Overload The thermal sensor of the drive triggered overload protection.
Cause		Possible solution
Load is too heavy		Reduce the load.
Overload occurred when operating at low speeds.		<ul style="list-style-type: none"> • Reduce the load • Replace the drive with a model that is one frame size larger. • Lower the carrier frequency (C6-02).
Excessive torque compensation.		Reduce the torque compensation gain (C4-01) until there is no speed loss but less current.
Output current fluctuation due to input phase loss		Check the power supply for phase loss.

LED Operator Display		Fault Name
<i>STo</i>	STo	Motor Pull Out or Step Out Detection Motor pull out or step out has occurred. Motor has exceeded its pull out torque.
Cause		Possible solution
The wrong motor code has been set.		<ul style="list-style-type: none"> • Enter the correct motor code for the PM being used into E5-01. • For special-purpose motors, enter the correct data to all E5 parameters according to the Test Report provided for the motor.
Load is too heavy		<ul style="list-style-type: none"> • Increase the value set to n8-55 (Load Inertia for PM). • Increase the value set to n8-51 (Pull-In Current during Accel/Decel for PM). • Reduce the load. • Increase the motor or drive capacity.
Load inertia is too heavy.		Increase n8-55 (Load Inertia for PM).
Acceleration and deceleration times are too short.		<ul style="list-style-type: none"> • Increase the acceleration and deceleration times (C1-01 through C1-08). • Increase the S-curve acceleration and deceleration times (C2-01).



WARRANTY

WARRANTY HOTLINE- 1800 602 243

THIS WARRANTY IS VALID IN AUSTRALIA ONLY

In the event of service being required, please call the **Mammoth Fan Support Hotline on 1800 602 243** between **9am & 5pm (EST) Monday to Friday**.

Please make sure you have all the Mammoth Fan details filled out at the end of the manual before making the call.

Every Mammoth fan is thoroughly inspected and tested before being released for sale. In addition to any warranty rights or conditions under statutory regulations, Mammoth Fans warrant all of its ceiling fans against defective workmanship and faulty materials for 5 years from the date of purchase. Mammoth Fans undertake, at its option, to repair or replace, free of charge, each product or part thereof on condition that;

- 1. The fan or relevant part has not been subjected to misuse, neglect, or been involved in an accident.**
- 2. The repairs are not required as a result of normal wear and tear.**
- 3. The product was installed by a licensed electrical contractor and to the guidelines outline in the manual.**
- 4. A copy of the original receipt of purchase is presented.**

Our goods come with guarantees that cannot be excluded under the Australian Consumer Law. You are entitled to a replacement or refund for a major failure and compensation for any other reasonably foreseeable loss or damage. You are also entitled to have the goods repaired or replaced if the goods fail to be of acceptable quality and the failure does not amount to a major failure.

Mammoth Fans cannot be held responsible for any repair other than those carried out by it or one of its Authorised Service Agents. Please keep this warranty information in a safe place. This information must be produced in the event of service being required.

Distributed by:

Beacon Lighting

140 Fulton Drive,
Derrimut, Victoria, 3026,
Australia

Ph **1300 289 808**

Email: warranty@beaconlighting.com.au

WARRANTY

Mammoth Fan WARRANTY INFORMATION

Mammoth Fan Support Hotline - 1800 602 243

Complete and retain this form for your personal records and warranty purposes.

NAME _____

ADDRESS _____

_____ POSTCODE _____

MODEL NUMBER _____

(PO# + DATE CODE Sticker here)

PO NUMBER or DATECODE _____

DATE OF PURCHASE _____

INSTALLING LICENSED ELECTRICIAN _____

LICENCE No. _____

ATTACH PROOF OF PURCHASE HERE

**THIS COMPLETED DETAIL PAGE SHOULD BE FILLED IN AND
EMAILED TO THE MAMMOTH SUPPORT WARRANTY TEAM PRIOR TO ANY
WARRANTY SERVICE BEING COMPLETE. APPROVAL FROM MAMMOTH
FANS MUST BE OBTAINED BEFORE WORK IS COMMENCED.**



